

CAD FILE:

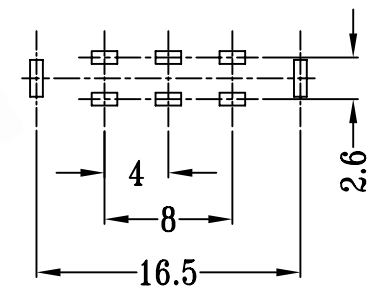
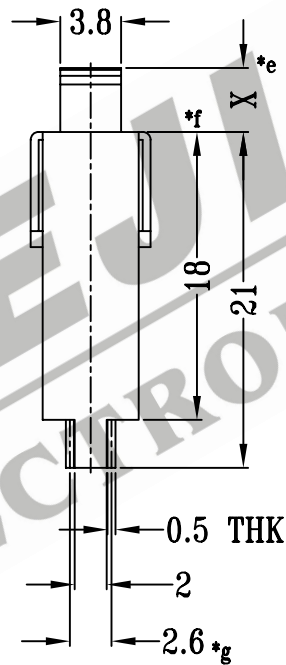
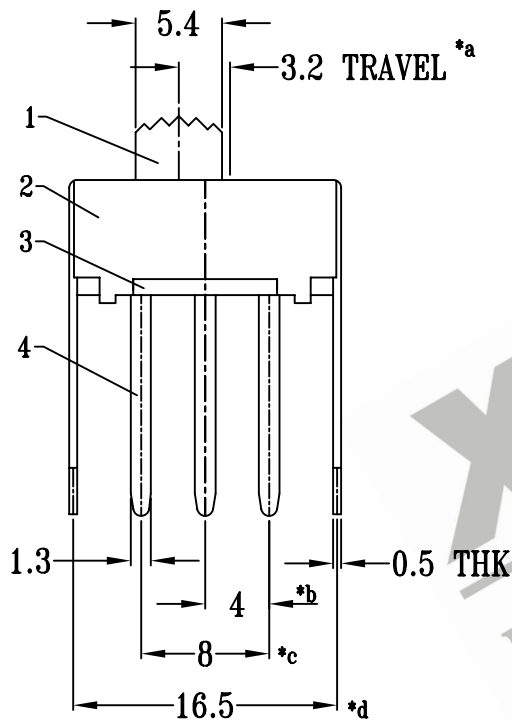
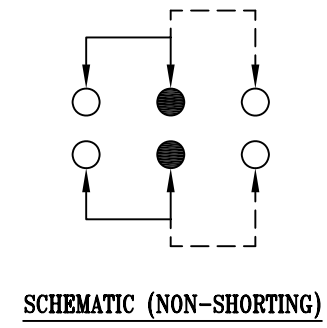
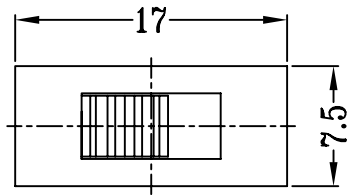

**P.C.B LAYOUT**

注:带"\*"表示关键尺寸(7个)

8					TOLERANCE UNLESS SPECIFIED	SHENZHEN XIEJIA ELECTRONICS CO.,LTD.				
7										
6	SPRING	STEEL WIRE	2	TEMPER	WITHIN: 1.5±0.1mm	ISSUE	DATE	DESCRIPTIONS		APPD.
5	CONTACT CLIP	BRASS STRIP	2	Ag PLATED	OVER : 1.5±0.2mm					
4	TERMINAL	BRASS STRIP	6	Ag PLATED OVER Ni PLATED	TITLE : VERTICAL SLIDE SWITCH	UNIT : MM		DRWG NO.: XJ-DR-SS22F20-00		
3	BASE	PHENOLIC RESIN	1	BLACK	MODEL: SS-22F20	SCALE: 2 : 1		DWN.	ZHOUYU	2004-4-18
2	FRAME	STEEL STRIP	1	Ni PLATED				CHK'D	FANGYING	2004-4-18
1	KNOB	POM	1	BLACK	ALL MATERIALS MUST BE COMPLIANT TO ROHS	APPD.		KANGXINAN	2004-4-18	
NO.	PART NAME	MATERIAL	Q'TY	FINISHING						